

# JIB500GR Main Features



- ✓ **3 MOVEMENTS AT THE SAME TIME**
- ✓ **DESIGNED FOR STEEL BEAMS HANDLING**
- ✓ **PLUG & PLAY SYSTEM**

## **180° TILT ANGLE**

The JIB can tilt up to 180°, allowing the operator to position it in the exact position needed



## **FULLY HYDRAULIC MANIPULATOR**

The JIB500GR is powered by the crane hydraulic system and is operated by the crane's radio remote control

## **360° ROTATION**

Continuous hydraulic 360° rotation



**JIB500GR**



**Jekko srl**  
Via Campardone, 1 - 31014 Colle Umberto (TV) Italy  
info@jekko.it - www.jekko-cranes.com

Product Catalog

# JIB500GR

**max** 230 kg

1650 x 1230 x 620 mm

The versatile grabber manipulator, with extremely precise movements. This tool dramatically increases productivity since a single operator can unload, handle and install a beam.



## Technical Information

Dimension	L x W x H	250 x 1080 x 1305 mm	
Weights		Name/ version	kg
	JIB500GR	JIB500GR	230
Movements		Tilt A	-57° / +65°
		Tilt B	-34° / +26°
		Rotation	360°
Capacity		Maximum Capacity	Max: 500 kg



**360° continuous rotation**

## Movements

### ROTATION

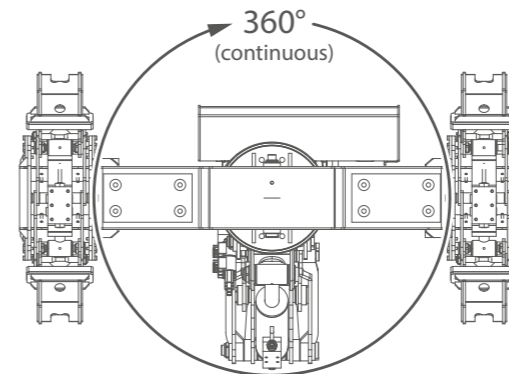

### TILT

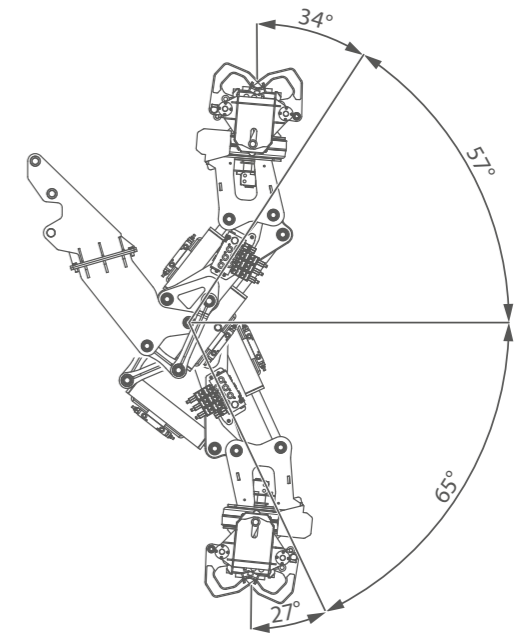

## Dimensions

